

CHARACTERISTICS

- Pull-out compact hood
- Inswing control
- Stainless steel, white or dark
- 90 cm model
- Double turbine motor
- Exhaust capacities; maximum in test conditions: 756 m³/h, free outlet: 540 m³/h, UNE-EN-61591: 303 m³/h
- Recommended for kitchens up to 10 m²
- 2 speeds
- Candle type lamps
- Metal filters
- Removable front panel
- Automatic switch on/off
- Sound level (UNE-EN 60704- 2-13): 46 dBA

TECHNICAL DRAWING

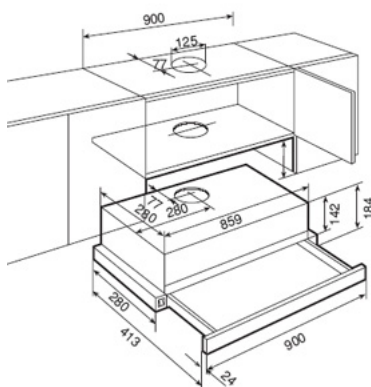

Electric Characteristics

Power supply (V) 220-240 / 50 Hz	•
Power supply (V) 127 / 60 Hz	-
Light power (W)	2 x 40
Motor power (W)	160
Maximum power (W)	240
Air outlet (ø mm)	120
Reduction outlet (ø 150 / ø 120)	•
Optional recirculation kit	•

Capacity and sound levels

Exhaust capacity, test conditions (m ³ /h)	756
Exhaust capacity, free outlet (m ³ /h)	540
Exhaust capacity, UNE EN 61591 (m ³ /h)	303
Sound power level dBA UNE EN 60704-2-13	60
Sound level (re 1pw UNE EN 60704-2-13) dB	46
Maximum recommended kitchen size (m ²)	10

Control panel

Touch control	-
Electronic	-
Push button	-
Mechanical slider	-
Mechanical inswing	•

Features

Number of motors	1
Double turbine motor	•
Armoured motor	-
Number of speeds	2
Stop delay timer	-
Easy-clean inside panel	-
Decorative filters	-
Metal filters	•
Operating pilot light	-
Filter saturation indicator	-
Humidity detector	-
Perimetric extraction system	-